

STATIC DIMENSIONS

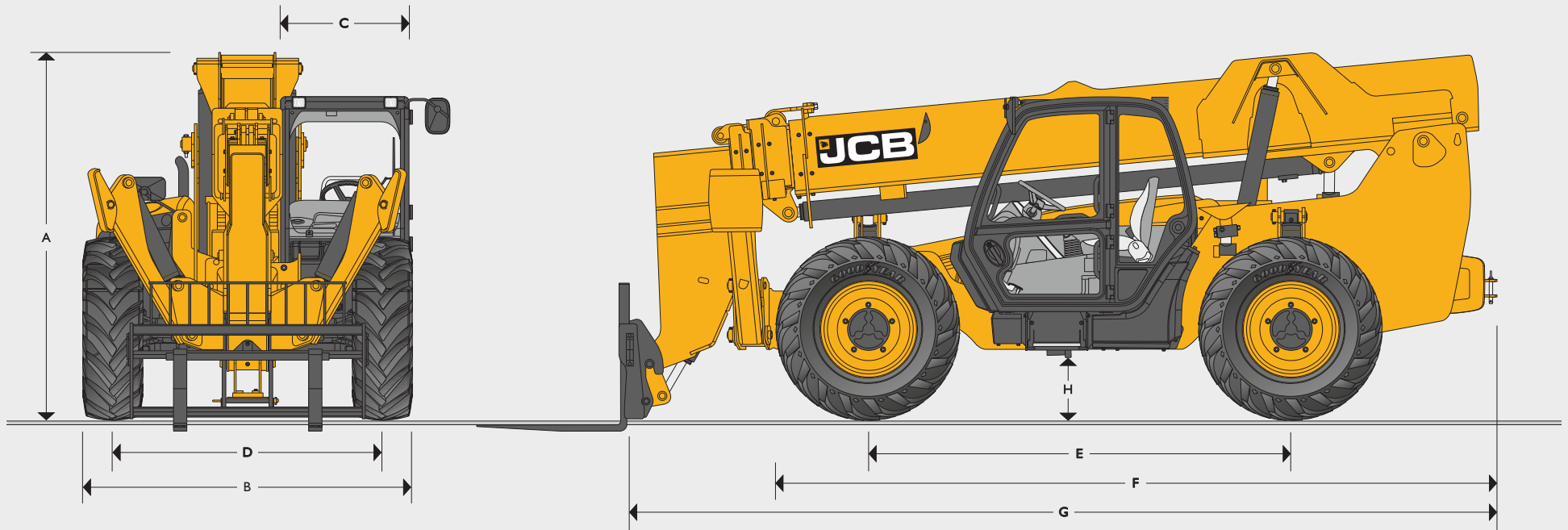

Machine model		506-36	507-42	509-42	510-56	512-56	514-56	516-42
A Overall height	ft-in (mm)	8-3 (2510)	8-3 (2525)	8-3 (2525)	8-10 (2692)	8-10 (2692)	8-11 (2716)	8-11 (2716)
B Overall width (over tyres)	ft-in (mm)	7-10 (2388)	7-10 (2388)	7-10 (2388)	8-1 (2471)	8-1 (2471)	8-1 (2475)	8-1 (2475)
C Inside width of cab	ft-in (mm)	3-1 (940)	3-1 (940)	3-1 (940)	3-1 (940)	3-1 (940)	3-1 (940)	3-1 (940)
D Front track	ft-in (mm)	6-4 (1936)	6-7 (2008)	6-7 (2008)	6-7 (2008)	6-7 (2008)	6-7 (2008)	6-7 (2008)
E Wheelbase	ft-in (mm)	10-4 (3150)	10-4 (3150)	10-4 (3150)	10-4 (3150)	10-4 (3150)	10-4 (3150)	10-4 (3150)
F Overall length to front tyres	ft-in (mm)	17-1 (5211)	17-8 (5386)	17-0 (5183)	17-9 (5406)	17-9 (5406)	18-4 (5596)	18-4 (5596)
G Overall length to front carriage	ft-in (mm)	19-5 (5918)	21-3 (6477)	20-7 (6274)	21-7 (6579)	21-7 (6579)	22-4 (6815)	22-4 (6,815)
H Ground clearance	ft-in (mm)	1-3½ (396)	1-3½ (396)	1-3½ (396)	1-5½ (444)	1-5½ (444)	1-5½ (444)	1-5½ (444)
Outside turn radius (over tyres)	ft-in (mm)	14-6 (4420)	13-9 (4191)	13-9 (4191)	14-1 (4293)	14-1 (4293)	14-4 (4365)	14-4 (4,365)
Weight	lb (kg)	20270 (9193)	21300 (9660)	22430 (10172)	29900 (13560)	30635 (13895)	32143 (14580)	32055 (14540)
Tires		13.00-24	14.00-24	14.00-24	17.5-25	17.5-25	17.5-25	17.5-25

LIFT PERFORMANCE

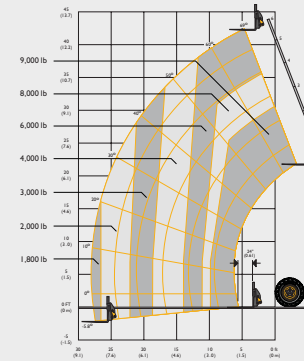
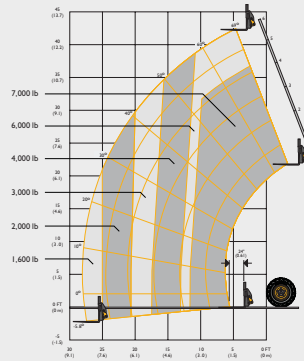
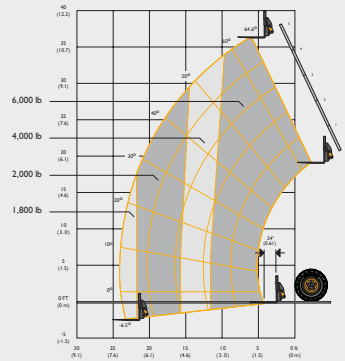

Machine model		506-36	507-42	509-42
Lift height	ft-in (mm)	36-4 (11070)	42-0 (12800)	42-0 (12800)
Maximum lift capacity	lb (kg)	6000 (2722)	7000 (3175)	9000 (4084)
Lift capacity to full height (on tires)	lb (kg)	6000 (2722)	6000 (2722)	6000 (2722)
Lift capacity at full reach	lb (kg)	1800 (816)	1600 (725)	1800 (816)
Reach at maximum lift height	ft-in (mm)	6-4 (1930)	4-11 (1500)	4-11 (1500)
Maximum forward reach	ft-in (mm)	24-0 (7310)	28-0 (8530)	28-0 (8530)
Frame sway left or right	degrees	10	10	10

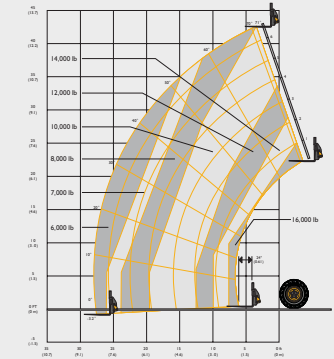
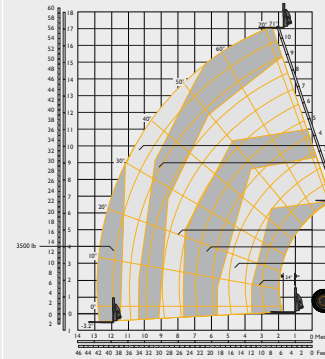
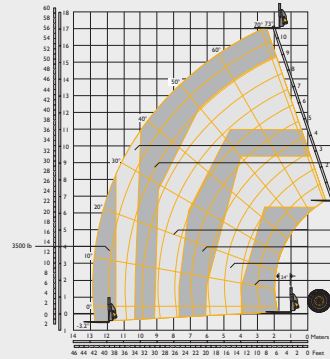
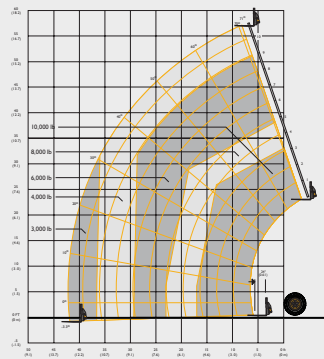

Lift data provisional.

Machine model		510-56	512-56	514-56	516-42
Lift height	ft-in (mm)	56-0 (17070)	56-0 (17070)	56-0 (17070)	42-0 (12800)
Maximum lift capacity	lb (kg)	10000 (4537)	12000 (5444)	14000 (6350)	16000 (7257)
Lift capacity to full height (on tires)	lb (kg)	3000 (1361)	4000 (1814)	4000 (1814)	6000 (2721)
Lift capacity to full height (on stabilizers)	lb (kg)	4000 (1814)	5000 (2268)	5000 (2268)	10000 (4537)
Lift capacity at full reach (on tires)	lb (kg)	300 (136)	300 (136)	500 (227)	2000 (907)
Lift capacity at full reach (on stabilizers)	lb (kg)	3000 (1360)	3500 (1587)	3500 (1587)	5000 (2267)
Reach at maximum lift height	ft-in (mm)	8-2 (2490)	8-2 (2490)	8-2 (2490)	4-11 (1500)
Maximum forward reach	ft-in (mm)	42-0 (12800)	42-0 (12800)	42-0 (12800)	28-0 (8530)
Frame sway left or right	degrees	10	10	10	10

ENGINE			
Machine model		506-36 / 507-42 / 509-42	509-42 / 510-56 / 512-56 / 514-56 / 516-42
Emissions level		Stage IV / Tier 4	Stage IV / Tier 4
Manufacturer		JCB	JCB
Displacement	ltr	4.4	4.4 / 4.8
No. of cylinders		4	4
Bore size	in (mm)	4.05" (103)	4.05" (103)
Stroke	in (mm)	5.0" (132)	5.0" (132)
Aspiration		Turbocharged cooled	Turbocharged cooled & Intercooler
Power rating			
Power @ 2200rpm	hp (kW)	74 (55)	109 (81)
Torque rating			
Torque @ 1300rpm	Nm	400	512
After treatment		N/A	SCR & DEF

SERVICE CAPACITIES			
Hydraulic tank	gallon (litres)		35 (132)
Coolant	gallon (litres)		6 (23)
Engine oil sump	gallon (litres)		3.6 (14)
Fuel tank	gallon (litres)		33.3 (126.3)
DEF tank (Adblue)	gallon (litres)		4.5 (17.3)

CYCLE TIMES								
Machine model		506-36	507-42	509-42	510-56	512-56	514-56	516-42
Lift	Seconds	11.2	11.7	13.8	18	18	16.8	16.4
Lower	Seconds	7.3	7.6	9.2	12.4	12.4	15.5	14.7
Extend	Seconds	8.5	9.7	9.7	24.2	24.2	22.7	13.6
Retract	Seconds	9.9	10.6	10.6	16.4	16.4	16.4	14.7
Bucket dump	Seconds	4	4	4	6.4	6.4	6.4	4.3
Bucket crowd	Seconds	3	3	3	3.7	3.7	4.5	4.2
Stabilizer down	Seconds	N/A	N/A	N/A	5.5	5.5	5.5	5.5
Stabilizer up	Seconds	N/A	N/A	N/A	4	4	4	4
Rear Axle Stabilization (RAS) System	Seconds	No	Yes	Yes	Yes	Yes	Yes	Yes

HYDRAULICS		
Two stage gear pump with suction strainer and filter		
Operating system pressure bar	psi (bar)	3770 (260)
Main hydraulics l/min	gal/min (l/min)	29 (110)
TRANSMISSION	JCB powershift transmission incorporating torque converter, bevel box and a 4 speed powershift gearbox in one resiliently mounted unit. Front and rear drive axles: JCB epicyclic hub reduction drive/steer axles with Max-Trac torque proportioning differentials. Travel speed: 15.5mph (25kph).	
BRAKES	Service brakes: Hydraulically activated, self-adjusting, oil-immersed in-board high back-off multi-disc type on front axle. Parking brake: Hand-operated disc brake on output of gearbox (55kW/74hp 81 kW/109hp) – oil immersed disc type).	
BOOM AND CARRIAGE	Boom is manufactured from high tensile steel. JCB self-levelling carriage pallet forks and a wide range of attachments.	
ELECTRICS	12v negative earth. 95 AH battery. 95 amp alternator. Full road lighting. Reversing light. Direction indicators.	
STEERING	Hydrostatic power steering with power track rods on both axles. Three steer mode options: front wheel steer; all wheel steer; crab steer: operated from in the cab by a selection lever.	
CAB	Quiet, safe and comfortable cab conforms to ROPS ISO 3471 and FOPS ISO 3449. Tinted glass all round with laminated front and roof screen. Roof bars, front, rear and roof screen wash/wipe and heater/screen demister. Audio-visual warning system for coolant temperature, water in fuel, engine oil pressure, air cleaner, battery charge, transmission oil temperature and pressure. Hour meter and road speed indicator. Engine temperature, fuel gauge and clock. Adjustable steering column with stalk bar powershift change and forward reverse shuttle. Throttle and brake pedal floor mounted. Adjustable suspension seat with adjacent park brake.	
OPTIONS AND ACCESSORIES	Front and rear working lights, rotating flashing beacon, fire extinguisher, radial industrial tyres, windscreen and roof guard, radio kit, air conditioning, carriage options available – contact your local dealer.	

ENERGY MASTER SPECIFICATION

Machine model	506-36	507-42	509-42	510-56	512-56	514-56	516-42
LED boom work lights (boom)	N/A	N/A	●	●	●	●	●
LED work lights (front and rear)	N/A	N/A	●	●	●	●	●
LED work lights (peripheral)	N/A	N/A	●	●	●	●	●
Single lever joystick	N/A	N/A	●	●	●	●	●
Fire extinguishers internal and external	N/A	N/A	●	●	●	●	●
Boom retract ARV	N/A	N/A	●	●	●	●	●
Auxiliary venting	N/A	N/A	●	●	●	●	●
Steel lower door	N/A	N/A	●	●	●	●	●
Solideal 14-24 solid fill	N/A	N/A	●	●	●	●	●
Mechanical tow hitch 6000 lbs	N/A	N/A	●	●	●	●	●
Boom sky hook	N/A	N/A	●	●	●	●	●
Mesh side screen (canopy cab option only)	N/A	N/A	○	○	○	○	○
Energy Master branding decal	N/A	N/A	●	●	●	●	●
Beacon strobe light	N/A	N/A	●	●	●	●	●

- Standard
- Option